

PT801

Underwater Position (Displacement)

Transducer

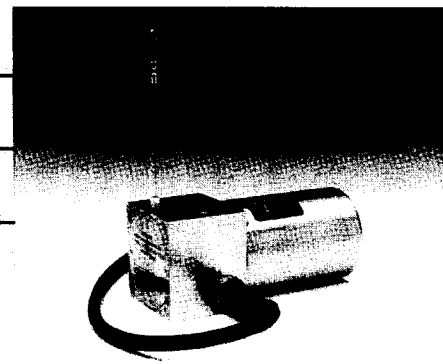

For use in hostile environments.

The PT801 is a position or displacement transducer for use underwater or in extremely hostile environments. It is frequently used in liquid food processing and paper mills. Designed for linear measurements up to 150 inches, it provides a voltage output by means of a precision potentiometer. AC or DC can be used for excitation. The PT801 can be used at depths up to 300 feet (130 psi). It is available in anodized aluminum or stainless steel to resist constant exposure to corrosive elements or prolonged use in salt water.

FEATURES:

- 0.1% accuracy standard (most ranges)
- Resolution of 0.002 inch range dependent
- Ranges from 0-2 to 0-150 inches full scale
- "A" circuit full scale output approximates input
- 4 to 20 ma output available⁴

Measurement Range	Position Trans. "A" Circuit Output	Approx. Cable Tension	Max. Cable Acceleration
Inches	MV/V/Inch	Ounces	Ext. G's Ret.
2	468.5	27	37 25
5	188.5	11	7 5
10	94.75	27	37 25
15	62.55	18	15 10
20	47.38	27	37 25
25	38.18	11	7 5
30	31.32	18	15 10
40	24.64	14	12 8
50	19.09	11	7 5
75	13.19	8	5 3
100	9.887	25	7 5
150	6.176	25	7 5

Specifications:

PERFORMANCE

Range ¹	0-2 to 0-150
Resolution:	
2 and 5 inch ranges	0.08% F.S. max.
10 inch and greater	0.008% F.S. max.
Accuracy: ²	
2 and 5 inch ranges	±0.25% F.S. typical
10 and 15 inch ranges	±0.15% F.S. typical
20 inch and greater	±0.10% F.S. typical
Thermal Coefficient of Sensing Element ³ :	
Span	83 P.P.M./°F
Zero	83 P.P.M./°F
Sensitivity	See Specification Table

ELECTRICAL CHARACTERISTICS

Input Resistance: For 2" & 5" units contact factory	
"A" Circuit	500 ohms std. Other options available
Output Resistance: For 2" & 5" units contact factory	
"A" Circuit	138 ohms max. Other options available
Excitation Voltage	25 volts max., AC or DC

PHYSICAL

Weight ⁵	20 ounces Aluminum, 50 ounces steel
Case Material	Aluminum (PT 801A) Stainless Steel (PT 801S)
Electrical Connection	36 inch cable (EM 21897 underwater connector and other connectors or cable leads optional)

ENVIRONMENTAL

Temperature	0° F to +200° F (-65° F to +250° F available)
Humidity	100% RH at 90° F
Vibration	up to 10 G's to 2000 Hz.

NOTES:

1. See Table for standard ranges.
2. Repeatability and best fit straight line errors combined R.S.S.
3. Over temperature range from 0°F to 200°F.
4. When ordering 4-20 ma option, specify circuit as - 420 in ordering information.
5. Weight specified is for 50 inch range or less.

Range (IN)	A DIM
2", 10", 20"	0.97 [24,6]
15", 30"	0.80 [20,3]
40"	0.67 [17,0]
5", 25", 50"	0.49 [12,4]
60"	0.34 [8,6]

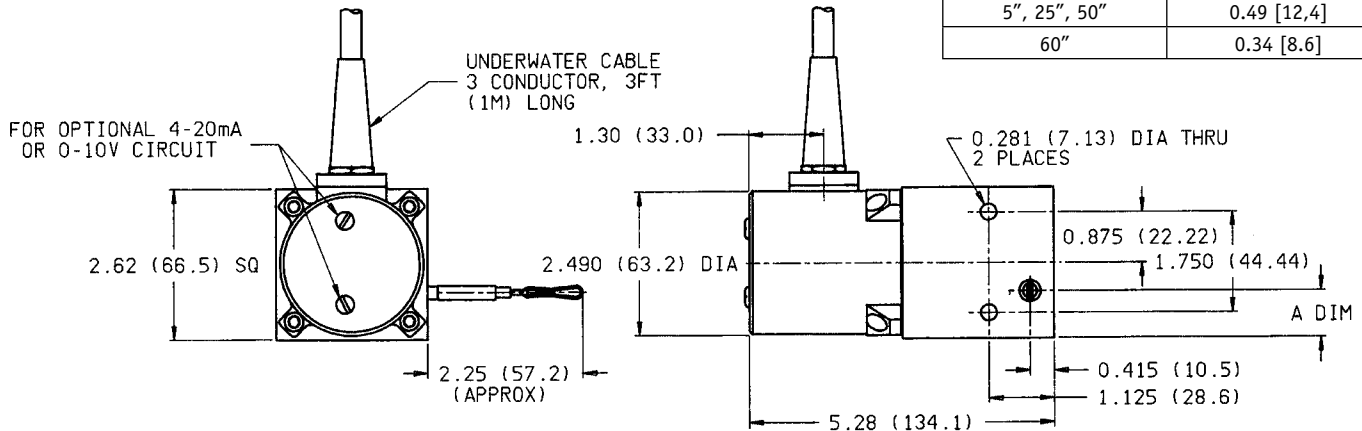

PT801- _____ - **6** **1** - _____ - _____ - _____ - _____ - **1** - _____
order code: **R** **A** **B** **C** **D** **E** **F** **G**

Sample Model Number:

PT801 - 0030 - 611 - 1111

R range:	30 inches
A enclosure:	stainless steel
C O-ring material:	nitrile
D sensing circuit:	500 ohm potentiometer
E output:	potentiometric
G electrical cable length:	3 feet

R - Full Stroke Range

- 0002 = 2 inches
- 0005 = 5 inches
- 0010 = 10 inches
- 0020 = 20 inches
- 0025 = 25 inches
- 0030 = 30 inches
- 0040 = 40 inches
- 0050 = 50 inches
- 0060 = 60 inches

A - Enclosure Material

- 6 = Stainless Steel

C - O-ring Material

- 1 = Nitrile, standard
- 2 = Ethylene Propylene
- 3 = Silicone
- 4 = Fluorocarbon (Viton)

D - Sensing Circuit

- 1 = 500 ohm potentiometer
- 2 = 1K ohm potentiometer
- 3 = 5K ohm potentiometer
- 4 = 10K ohm potentiometer

E - Output

- 1 = potentiometric or bridge output
- 2 = 4-20 mA, output increasing with cable extension*
- 3 = 20-4 mA, output increasing with cable retraction*
- 4 = 0-10 VDC, output increasing with cable extension*
- 5 = 0-5 VDC, output increasing with cable extension*
- 6 = 10-0 VDC, output increasing with cable retraction*
- 7 = 5-0 VDC, output increasing with cable retraction*

** Note! available only when D = 1*

G - Electrical Cable Length

- 1 = 3 ft. cable
- 2 = 6 ft. cable
- 3 = 7 ft. cable
- 4 = 10 ft. cable
- 5 = 12 ft. cable
- 6 = 15 ft. cable
- 7 = 20 ft. cable
- 8 = 25 ft. cable
- B = 50 ft. cable
- C = 75 ft. cable
- D = 100 ft. cable
- E = 200 ft. cable